

U00X ULTRASONIC LEVEL SWITCH

INSTALLATION AND OPERATIONS MANUAL

Ultrasonic Liquid Level Switches
For Non-Hazardous Locations

For Models:
U002, U003 & U004



SOLUTIONS WITH INNOVATION

AN INNOVATIVE SENSING COMPANY

ISO 9001:2008 CERTIFIED



READ THIS MANUAL PRIOR TO INSTALLATION

This manual provides information on the **U00X Ultrasonic Liquid Level Switch**. It is important that all instructions are read carefully and followed sequentially. Detailed instructions are included in the **Complete Installation** section of this manual.

Conventions Used in this Manual

Certain conventions are used in this manual to convey specific types of information. General technical material, support data and safety information are presented in narrative form. The following styles are used for notes, cautions and warnings:

Notes

Notes contain information that augments or clarifies an operating step. Notes do not normally contain actions and often follow the procedural steps to which they refer.

Cautions

Cautions alert the technician to special conditions that could injure personnel, damage equipment, or reduce a component's mechanical integrity. Cautions are also used to alert the technician of unsafe practices, the need for special protective equipment, or specific materials. In this manual, a caution indicates a potentially hazardous situation which, if not avoided, may result in minor to moderate injury.

Warnings

Warnings identify potentially dangerous situations, or serious hazards. In this manual, a warning indicates an imminently hazardous situation which, if not avoided, may result in serious injury or death.

Safety Messages

Follow all standard industry procedures for servicing electrical and computer equipment when working with, or around high voltage. Always shut off the power supply before touching any components. Although high voltage is not present in this system, it may be present in other systems.

Electrical components are sensitive to electrostatic discharge. To prevent equipment damage, observe all safety precautions when working with electrostatic-sensitive components.

WARNING!

EXPLOSION HAZARD! DO NOT CONNECT OR DISCONNECT THE TRANSMITTERS UNLESS THE POWER HAS BEEN SWITCHED OFF.

Low Voltage Directive

If the equipment is used in a manner not specified by the manufacturer, protection provided by equipment may be impaired.

Notice of Copyright and Limitations

Copyright © 2016 Solutions With Innovation, LLC;
All rights reserved.

Solutions With Innovation reserves the right to make changes to the product described in this manual at any time without notice. Solutions With Innovation makes no warranty with respect to the accuracy of the information in this manual.

Warranty

All Solutions With Innovation Electronic Level and Flow Controls are warranted free of defects in materials and workmanship for one full year from the date of the original factory shipment. If returned within the warranty period; and, upon factory inspection of the control, the cause of the claim is determined to be covered under the warranty; then, Solutions With Innovation will repair or replace the product at no cost to the purchaser (or owner) other than transportation.

Solutions With Innovation shall not be liable for misapplication, labor claims, direct or consequential damage, or expenses arising from the installation or use of the equipment. There are no other warranties expressed or implied, except special written warranties covering specific Solutions With Innovation products.

Quality Assurance

The Quality Assurance System in place at Solutions With Innovation guarantees the highest level of quality throughout the company. Solutions With Innovation is committed to providing full customer satisfaction; both in quality products and in quality service.

Contacts

Phone: 203-729-6434 *Mon-Fri, 9 AM - 5 PM EST*
Fax: 203-729-0541 *for General Inquiries*
Email: sales@innovativesensing.com

U00X ULTRASONIC LEVEL SWITCH

For Non-Hazardous Locations

TABLE OF CONTENTS

1.0 Installation

1.1 Unpacking.....	4
1.2 Electrostatic Discharge Handling Procedure.....	4
1.3 Before You Begin.....	4
1.3.1 Site Preparation.....	4
1.3.2 Equipment and Tools.....	4
1.4 Mounting.....	5
1.4.1 Horizontal Installation.....	5
1.4.2 Vertical Installation.....	5
1.4.3 Nozzle or Pipe Installation.....	5
1.5 Wiring.....	6
1.5.1 U002: Current Shift Output.....	6
1.5.2 U003: Relay Output.....	6
1.5.3 U004: Relay Output with Fail-Safe Option.....	7

2.0 Preventative Maintenance

2.1 Maintenance Procedure.....	8
2.1.1 Inspect Unit Periodically.....	8
2.1.2 Inspect Connections Monthly.....	8
2.2 What To Avoid.....	8

3.0 Reference Information

3.1 Description.....	9
3.2 Theory of Operation.....	9
3.3 Troubleshooting.....	10
3.3.1 Unit Problems.....	10
3.3.2 Replacement Units.....	10
3.4 Specifications.....	11
3.4.1 Functional.....	11
3.4.2 Physical.....	11
3.5 Model Configurator.....	12
3.5.1 Additional Options.....	12
3.6 Notes.....	13



1.0 INSTALLATION

This section provides detailed procedures on properly installing and configuring the U00X Ultrasonic Liquid Level Switch.

CAUTION! IF THE EQUIPMENT IS USED IN A MANNER NOT SPECIFIED BY THE MANUFACTURER, PROTECTION PROVIDED BY THE EQUIPMENT MAY BE IMPAIRED.

1.1 UNPACKING

Unpack the instrument, carefully. Make sure that all components have been removed from the packing material. Inspect all components for damage. Report any concealed damage to the carrier within 24 hours of receiving. Compare the contents with the packing slip and report any discrepancies to the factory immediately. Record the sales order number and/or serial number for future reference when ordering parts.

Before Proceeding to Installation, Complete the Following:

- Inspect all components for damage. Report any damage to the carrier within 24 hours of receiving.
- Record the model and serial numbers for future reference when ordering parts.

Model Number _____

Serial Number _____

1.2 ⚠ ELECTROSTATIC DISCHARGE (ESD) HANDLING PROCEDURE



Solutions With Innovation's electronic instruments are manufactured to the highest quality standards. These instruments use electronic components that may be damaged by static electricity present in most work environments. Make sure that all electrical connections are completely secure and none are partial or floating. Ground all equipment to a good, earth ground.

1.3 BEFORE YOU BEGIN

1.3.1 Site Preparation

- 1 Verify that the designated mounting area for the U00X Ultrasonic Liquid Level Switch is clean and free of any particulate matter. Refer to **Section 1.4: Mounting**.
- 2 Ensure that the wires are mounted properly to prevent kinks and pinching between components. When installing the U002, U003 or U004, all applicable electrical codes and wiring procedures must be observed. Refer to **Section 1.5: Wiring**.

1.3.2 Equipment and Tools

No special equipment or tools are required to install the U00X Ultrasonic Liquid Level Switch.

The Following Are Recommended:

- Adjustable Wrench
- Proper Gasket (*For Flanged Units*)

1.4 MOUNTING

The U002, U003 and U004 Ultrasonic Liquid Level Switches can be mounted in a variety of positions. By ensuring the vertical orientation of the transducer gap, the unit will facilitate maximum performance in difficult applications.

1.4.1 Horizontal Installation

- 1 Apply thread tape or pipe compound onto the unit's mounting thread.
- 2 Carefully, thread the transducer into the opening and tighten with a wrench. **DO NOT OVER-TIGHTEN.**
- 3 Orient the transducer gap as vertical as possible to allow for the proper drainage of fluid from the gap. **DO NOT OVER-TIGHTEN.**

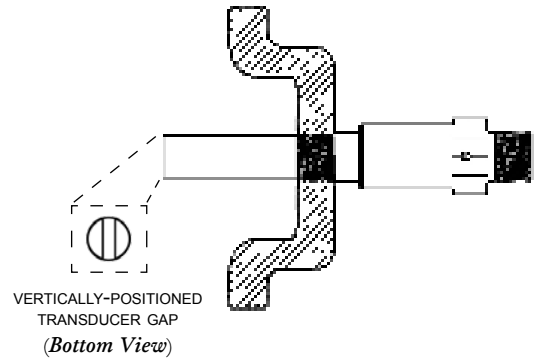

1.4.2 Vertical Installation

- 1 Apply thread tape or pipe compound onto the unit's mounting thread.
- 2 Carefully, thread the transducer into the opening and tighten with a wrench. **DO NOT OVER-TIGHTEN.**

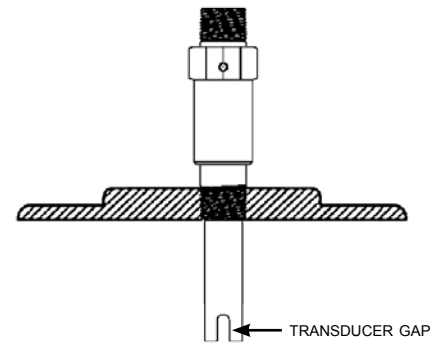

1.4.3 Nozzle or Pipe Installation

- 1 Apply thread tape or pipe compound onto the unit's mounting thread.
- 2 Carefully, thread the transducer into the opening and tighten with a wrench. For flanged connections, bolt the unit to the mating flange with a proper gasket. **DO NOT OVER-TIGHTEN.**
- 3 Position the transducer gap to extend **at least 1"** into the interior tank wall. If the switch is mounted horizontally, orient the transducer gap as vertical as possible to ensure proper drainage from the gap. **DO NOT OVER-TIGHTEN.**

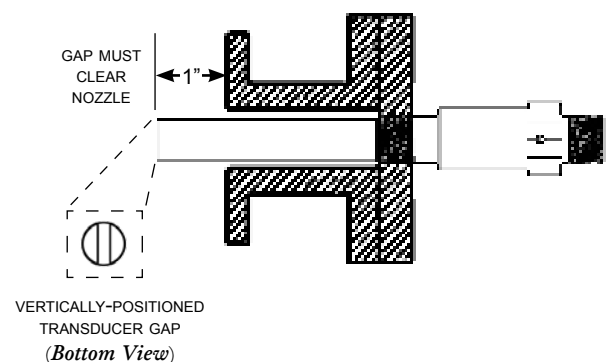

1.5 WIRING

⚠ WARNING! DO NOT DISCONNECT THE EQUIPMENT UNLESS THE POWER IS SWITCHED OFF. DO NOT ATTEMPT TO WIRE THE EQUIPMENT UNLESS THE POWER IS SWITCHED OFF.

⚡ CAUTION! ALL WIRING, CONDUIT AND ELECTRICAL FITTINGS MUST CONFORM TO ALL LOCAL ELECTRICAL CODES CORRESPONDING TO THE INSTALLATION LOCATION.

1.5.1 U002: Current Shift Output

- The three (3) wiring terminations for the U002 are 18 AWG.
- Connect the wires to field wiring that is 14 to 22 AWG.

Field Wiring Connection:

- 1 Install the conduit into the 3/4" NPT connection.
- 2 Use an approved seal fitting to prevent moisture from entering the internal switch.
- 3 Connect the loop power to the unit via the **RED (+)** and **BLACK (-)** wires.
- 4 Connect the **GREEN** wire to grounded earth.

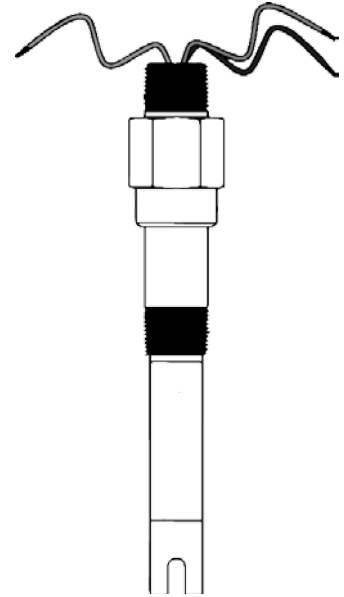

1.5.2 U003: Relay Output

- The six (6) wiring terminations for the U003 are 18 AWG.
- Connect the wires to field wiring that is 14 to 22 AWG.

Field Wiring Connection:

- 1 Install the conduit into the 3/4" NPT connection.
- 2 Use an approved seal fitting to prevent moisture from entering the internal switch.
- 3 Connect a 12 to 35 VDC power supply to the unit via the **RED (+)** and **BLACK (-)** wires.
- 4 Connect the **GREEN** wire to grounded earth.
- 5 The SPDT relay wire connections (*dry sensor tip*):
 - **ORANGE** wire: N.O. (*Normally-Open*)
 - **BLUE** wire: N.C. (*Normally-Closed*)
 - **YELLOW** wire: COM (*Common*)

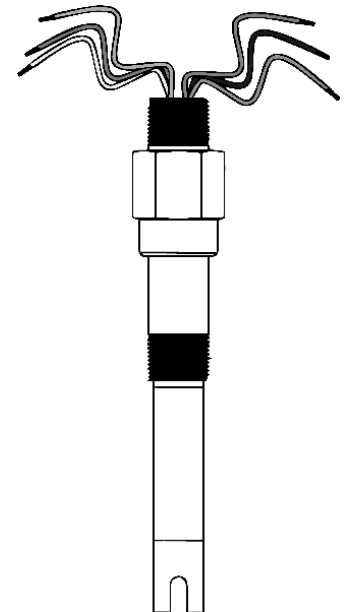

1.5.3 U004: Relay Output with Fail-Safe Option

- The six (6) wiring terminations for the U004 are 18 AWG.
- Connect the wires to field wiring that is 14 to 22 AWG.

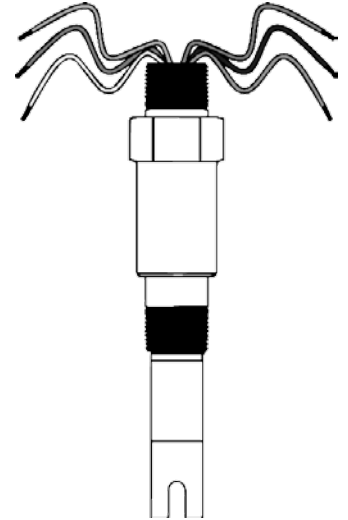

Field Wiring Connection:

- 1 Install the conduit into the 3/4” NPT connection.
- 2 Use an approved seal fitting to prevent moisture from entering the internal switch.
- 3 Connect a 12 to 16 VDC or 24 to 30 power supply to the unit via the **RED (+)** and **BLACK (-)** wires depending on the input.
- 4 Connect the **GREEN** wire to grounded earth.

Power On: “Normal” Operation

- **Input Voltage:** 12 to 16 VDC or 24 to 30 VDC
- **Power Consumption:** Less Than 1 Watt
- **Relay Contact Ratings:** 1 Amp at 30 VDC; 0.5 Amp at 125/150 VDC

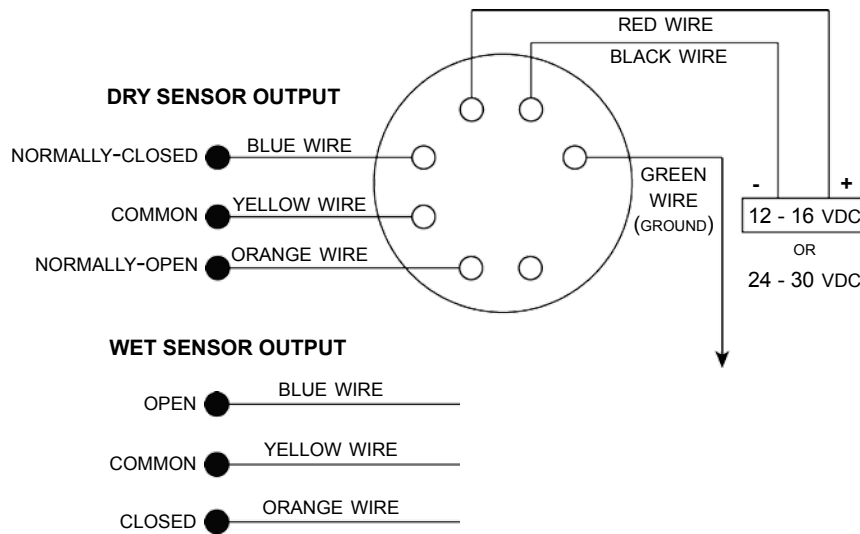

Power Loss: “Fail-Safe” Operation

- If the **Input Voltage** drops to *less than* 3 VDC or 16 VDC, the “Fail-Safe” mode engages.
- If the **Input Voltage** is restored to *greater than* 12 VDC or 24 VDC, “Normal” operation resumes.

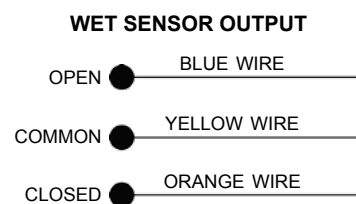
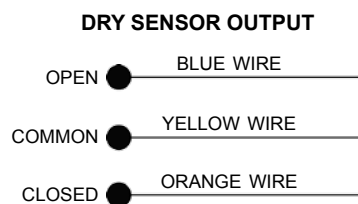

2.0 PREVENTATIVE MAINTENANCE

Periodic inspections are necessary to maintain the proper functionality of the U00X Ultrasonic Liquid Level Switch. The switch is an extremely compact level device with its electronics enclosed directly above the stainless steel transducer inside the extension piece. A systematic program of preventative maintenance should be implemented at the time of installation. If the following instructions are completed routinely, the ultrasonic switch will provide continuous liquid level detection.

2.1 MAINTENANCE PROCEDURES

2.1.1 Inspect Unit Periodically

The U002, U003 and U004 Ultrasonic Liquid Level Switches are designed to operate in various fluids. Over time, media can build up in or around the transducer gap. As a result, their level detection capabilities may be impaired.

- Inspect the transducer gap for dense foam, dried product or any other potential build-up.
- Inspect all electrical connections and seals for possible damage.
- Replace the unit, if necessary.

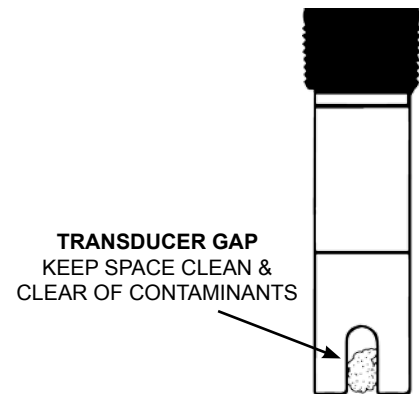

2.1.2 Inspect Connections Monthly

U00X Ultrasonic Liquid Level Switches may be vulnerable to excessive heat and moisture. Under these conditions, the electrical wire insulation can periodically break or peel away. As a result, the bare wires may become exposed to the elements and incur damages.

- Inspect all wiring and remove the unit from service if any wires exhibit signs of brittle insulation.
- Inspect all electrical connections to ensure tightness.

2.2 WHAT TO AVOID

- ⚠ NEVER ATTEMPT TO FIX ANY OF THE UNIT'S INTERNAL COMPONENTS.** *There are no replacement parts for the unit. Tampering with the unit will void the manufacturer's warranty.*
- ⚠ NEVER USE A UNIT THAT SHOWS EVIDENCE OF SURFACE OR ELECTRICAL DAMAGE.** *Remove the unit from service immediately and replace it with a new one.*
- ⚠ NEVER CONNECT OR DISCONNECT EQUIPMENT UNLESS POWER HAS BEEN SWITCHED OFF.** *Potential explosion hazard. Always verify that the area is non-hazardous when connecting or disconnecting the unit.*

3.0 REFERENCE INFORMATION

This section illustrates an overview of the U00X Ultrasonic Liquid Level Switch operation, as well as information on troubleshooting common problems, agency approval listings and detailed physical, functional and performance specifications.



3.1 DESCRIPTION

The U002, U003 and U004 Ultrasonic Liquid Level Switches are compact integral units that utilize pulsed signal technology to perform high or low level measurement in a wide variety of fluid applications. The U00X Ultrasonic Liquid Level Switch is intended for use in non-hazardous locations, however, additional models are available for use in hazardous locations.

3.2 THEORY OF OPERATION

U00X Series Liquid Level Switches utilize ultrasonic energy to detect the presence or absence of liquid within a tip-sensitive transducer gap. Their operation is based on the principle of *Contact Ultrasonic Technology*, where high-frequency sound waves are easily transmitted across a wet transducer gap, but become attenuated if the gap is dry.

Two piezoelectric crystals (one transmitter and one receiver) are encapsulated at the tip of the transducer. If a voltage is applied to the crystals, their ceramic composition vibrates. The transmitter crystal converts the voltage into an ultrasonic signal that travels across the liquid-filled gap where it is detected by the receiver crystal. The ultrasonic signal is then converted back into an electrical signal that indicates the presence of liquid to the electronic components. If no liquid is present, the transmitted signal fails to travel across the dry gap.

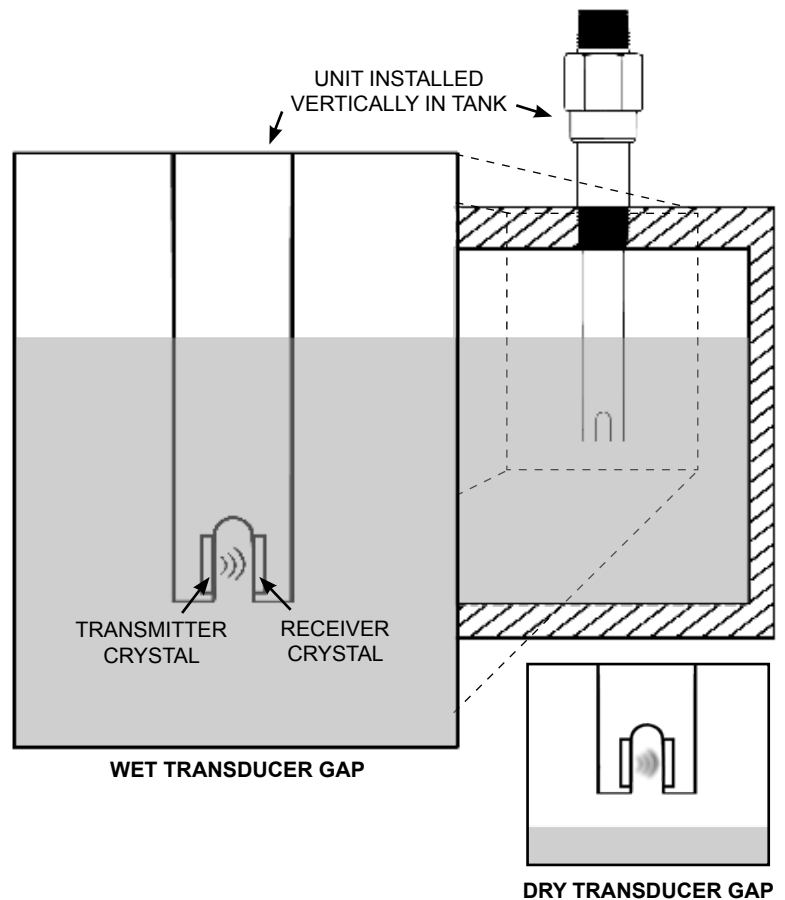

3.3 TROUBLESHOOTING

The U00X Ultrasonic Liquid Level Switch is designed and manufactured for trouble-free performance across a wide range of operating conditions. Common transmitter problems are discussed in terms of their symptoms and recommended corrective actions.

⚠ WARNING! DO NOT CONNECT OR DISCONNECT THE EQUIPMENT UNLESS POWER HAS BEEN SWITCHED OFF OR THE AREA IS KNOWN TO BE NON-HAZARDOUS.

3.3.1 Unit Problems

SYMPTOM	PROBLEM	SOLUTION
THERE IS NO CHANGE IN OUTPUT BETWEEN THE WET AND DRY GAP.	THE TRANSDUCER GAP IS CLOGGED.	VERIFY THAT THE TRANSDUCER GAP IS NOT PLUGGED WITH SOLIDS, DENSE FOAM ON THE SURFACE OR DRIED PRODUCT IN THE GAP. THE UNIT MAY NOT FUNCTION PROPERLY IF THIS CONDITION EXISTS.
THERE IS NO CHANGE IN OUTPUT BETWEEN THE WET AND DRY GAP.	ELECTRICAL FAILURE.	CHECK THE WIRING TO ENSURE THE PROPER INPUT VOLTAGE IS SUPPLIED.
THE SWITCH IS CHATTERING.	TURBULENCE.	CHECK FOR TURBULENCE. RELOCATE THE SWITCH OR ISOLATE IT TO PREVENT INTERFERENCE.
THE SWITCH IS CHATTERING.	THERE IS EXCESSIVE AERATION.	CHECK FOR EXCESSIVE AERATION.
THE SWITCH IS CHATTERING.	ELECTRICAL FAILURE.	CHECK THE WIRING TO ENSURE THE PROPER INPUT VOLTAGE IS SUPPLIED.

 *If you are still in doubt about the condition or performance of your control, consult the factory for further instructions.*

3.3.2 Replacement Units



Due to the epoxy-cured design of the U002, U003 and U004 Ultrasonic Liquid Level Switches, replacement parts cannot be installed into the existing unit. If the transducer becomes damaged or loses functionality, consult the manufacturer to order a unit replacement.

When Ordering Replacement Units:

- Identify the unit's model number and/or serial number. Refer to the information listed in **Section 1.1: Unpacking**.
- Reference the detailed listing of model number specifications and additional options in **Section 3.6 Model Configurator**.

3.4 SPECIFICATIONS

3.4.1 Functional

INPUT	
MEASUREMENT PRINCIPLE:	Ultrasonic Sound Waves Converted to Output Signal
MEASURED VARIABLE:	Wet or Dry Gap Actuation
INDICATION LENGTH:	2 1/8" to 100" (5.39 cm to 254 cm)
POWER:	U002: 12 to 35 VDC U003: 12 to 35 VDC U004: 12 to 16 VDC or 24 to 30 VDC
OUTPUT	
SIGNAL:	U002 Current Shift: Dry Gap: 8 mA (± 1 mA) Wet Gap: 16 mA (± 1 mA) U003 Relay Output: SPDT: 1 Amp at 30 VDC; 0.5 Amp at 150/125 VAC/DC U004 Relay Output: SPDT: 1 Amp at 30 VDC; 0.5 Amp at 150/125 VAC/DC
CABLING:	12" (305 mm) Flying Leads of 18 AWG Wire
ENVIRONMENTAL	
OPERATING TEMPERATURE:	-40° to +185° F (-40° to +85° C)
AMBIENT TEMPERATURE:	-40° to +185° F (-40° to +85° C)
PRESSURE:	316 Stainless Steel: 2,000 PSIG (138 bar) Hastelloy C: 2,000 PSIG (138 bar) CPVC: 200 PSIG (13.8 bar) PVDF: 50 PSIG (3.4 bar)
INGRESS PROTECTION:	NEMA 4X
PERFORMANCE	
CRYSTAL FREQUENCY:	2 MHz, Pulsed
RESPONSE TIME:	Less Than 1/2 Second
POWER CONSUMPTION:	Less Than 1 Watt
MATERIALS OF CONSTRUCTION	
ENCLOSURE (OPTIONAL):	Die-Cast Aluminum
MOUNT, EXT. TUBE & SENSOR TIP:	316 Stainless Steel, Hastelloy C, CPVC, or PVDF

3.4.2 Physical

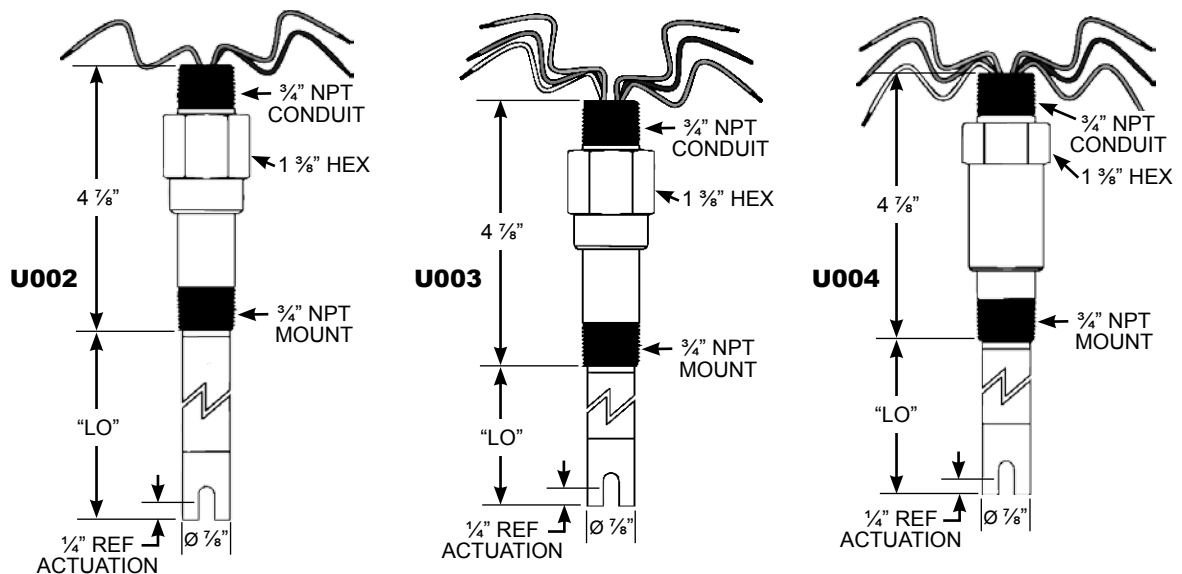

3.5 MODEL CONFIGURATOR

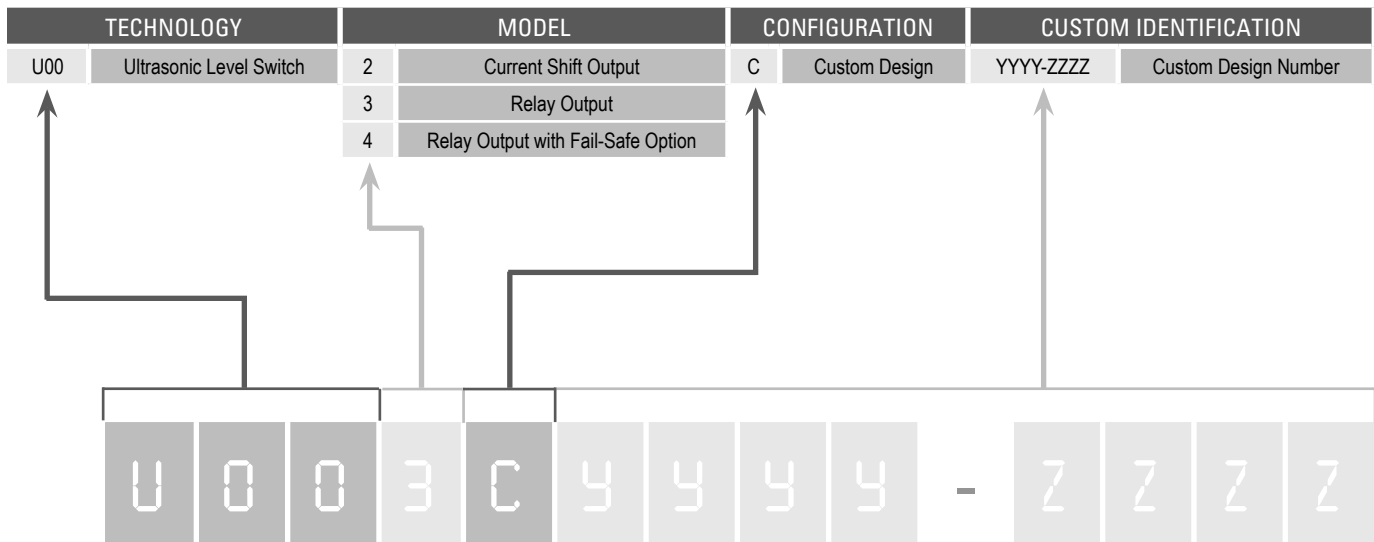

3.5.1 Additional Options

AVAILABLE ENCLOSURES	
No Junction Box: <i>Standard Probe & Mount Assembly</i>	
With Junction Box: <i>Die-Cast Aluminum Enclosure</i>	
AVAILABLE PROCESS CONNECTIONS	
¾" NPT	1" #150 ANSI Flange
1" NPT	1 ½" #150 ANSI Flange
1 ¼" NPT	2" #150 ANSI Flange
1 ½" NPT	2 ½" #150 ANSI Flange
2" NPT	3" #150 ANSI Flange
2 ½" NPT	4" #150 ANSI Flange
3" NPT	1" #300 ANSI Flange
4" NPT	1 ½" #300 ANSI Flange
1" Sanitary Flange	2" #300 ANSI Flange
2" Sanitary Flange	2 ½" #300 ANSI Flange
2 ½" Sanitary Flange	3" #300 ANSI Flange
3" Sanitary Flange	4" #300 ANSI Flange
4" Sanitary Flange	

3.6 NOTES

ASSURED QUALITY & SERVICE COST LESS

Service Policy

Owners of Solutions With Innovation products may request a return of the product, or any part of the product for complete rebuilding or replacement. Units will be rebuilt or replaced promptly. Products returned under the SWI Service Policy must be returned by prepaid transportation. Solutions With Innovation will repair or replace the product at no cost to the purchaser (or owner) other than transportation if:

- 1 Returned within the warranty period; and
- 2 Factory Inspection finds the cause of the claim to be covered under the warranty.

If the problem is due to circumstances beyond Solutions With Innovation's liability, or is NOT covered by the warranty, there will be charges for labor in addition to the parts required to rebuild or replace the equipment.

In rare cases, it may be expedient to ship replacement parts; or in extreme cases, an entire product before the damaged product is returned. If a quick replacement service is necessary, notify the manufacturer of the damaged product's model and serial number. In such cases, credit for the returned materials will be determined on the applicability of the warranty.

No claims for misapplication, labor, direct or consequential damage will be allowed.

Return Material Procedure

In order to efficiently process any returned materials, it is essential that a *Return Material Authorization* (RMA) number be obtained from the manufacturer prior to an item's return. RMA's can be issued through local representatives, or by contacting the factory directly.

Please supply the following information:

- 1 The Company's Name
- 2 Description of the Material
- 3 Product Serial Number
- 4 Reason for Return
- 5 Product's Application

Used units must be properly cleaned in accordance with OSHA standards before it is returned to the manufacturer. A *Material Safety Data Sheet* (MSDS) must accompany units or materials that were used in any type of media. All return shipments to the factory must be by done via prepaid transportation. All product replacements will be shipped F.O.B. manufacturer.



SOLUTIONS WITH INNOVATION

AN INNOVATIVE SENSING COMPANY

ISO 9001:2008 CERTIFIED

BULLETIN: IS-9410.6
EFFECTIVE: 4/16

